

# LOW COST DYNAMIC DRIVE SCHEME FOR REFLECTIVE BISTABLE CHOLESTERIC LIQUID CRYSTAL DISPLAYS

*J. Ruth, R. Hewitt, P. Bos*

Liquid Crystal Institute  
Kent State University  
Kent, OH 44242

# Outline

- Reflective bistable cholesteric liquid crystals
  - Display basics
- Low cost dynamic drive scheme
  - Design and implementation

# Reflective Bistable Cholesteric LCDs

- Wide viewing angle
- High contrast (at least 20:1)
- Good performance in high ambient light conditions

# Cholesteric Liquid Crystal Textures

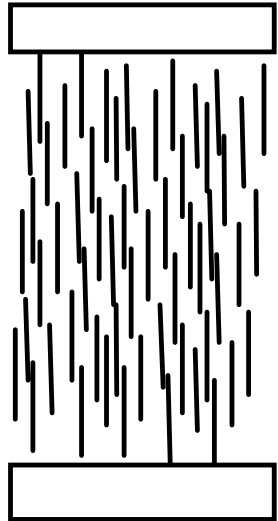

**Homeotropic  
Texture**

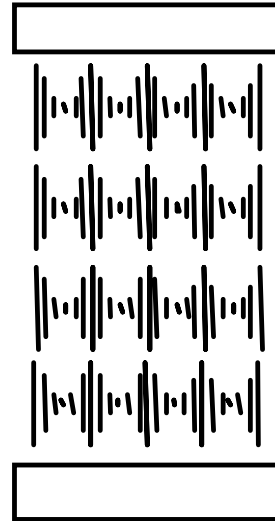

**Focal Conic  
Texture**

(Transparent)

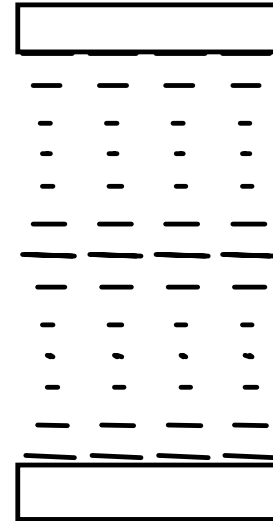

**Transient Planar  
Texture**

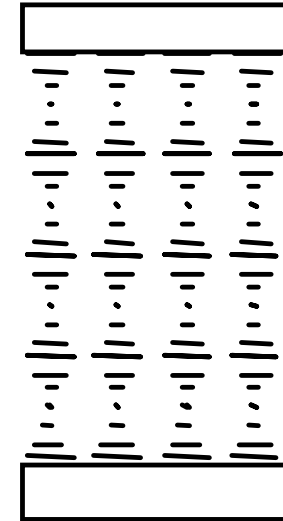

**Planar  
Texture**

(Reflective)

# Cholesteric Texture Transitions

- Drive scheme is based on controlled relaxation from the homeotropic texture
- Two mechanisms:
  - Homeotropic - Focal Conic (Transparent)
    - Nucleation induced transition
  - Homeotropic - Planar (Reflective)
    - Continuous transition via initial conical deformation and an intermediate transient planar texture

# Drive Schemes

## Conventional Drive

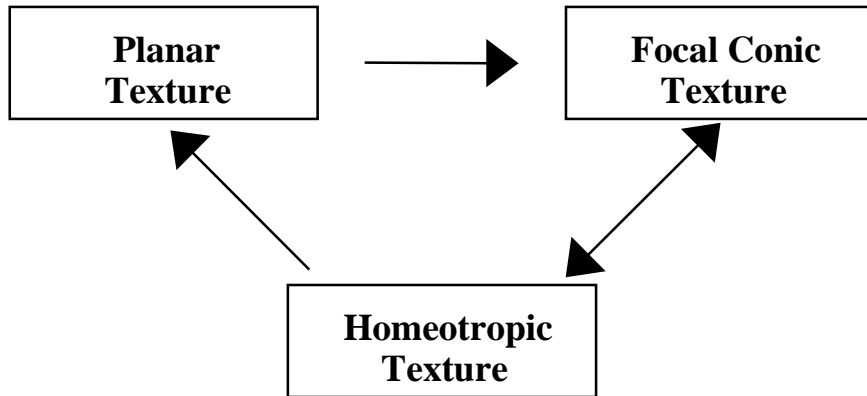

## Dynamic Drive

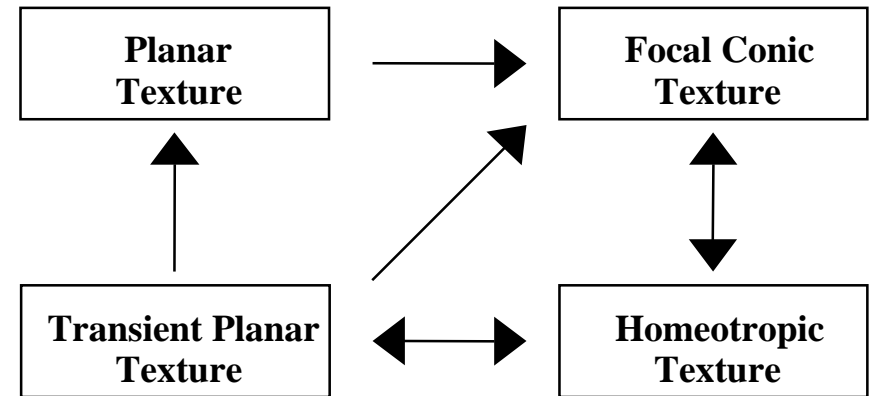

# Original Dynamic Drive Scheme Pixel Waveforms

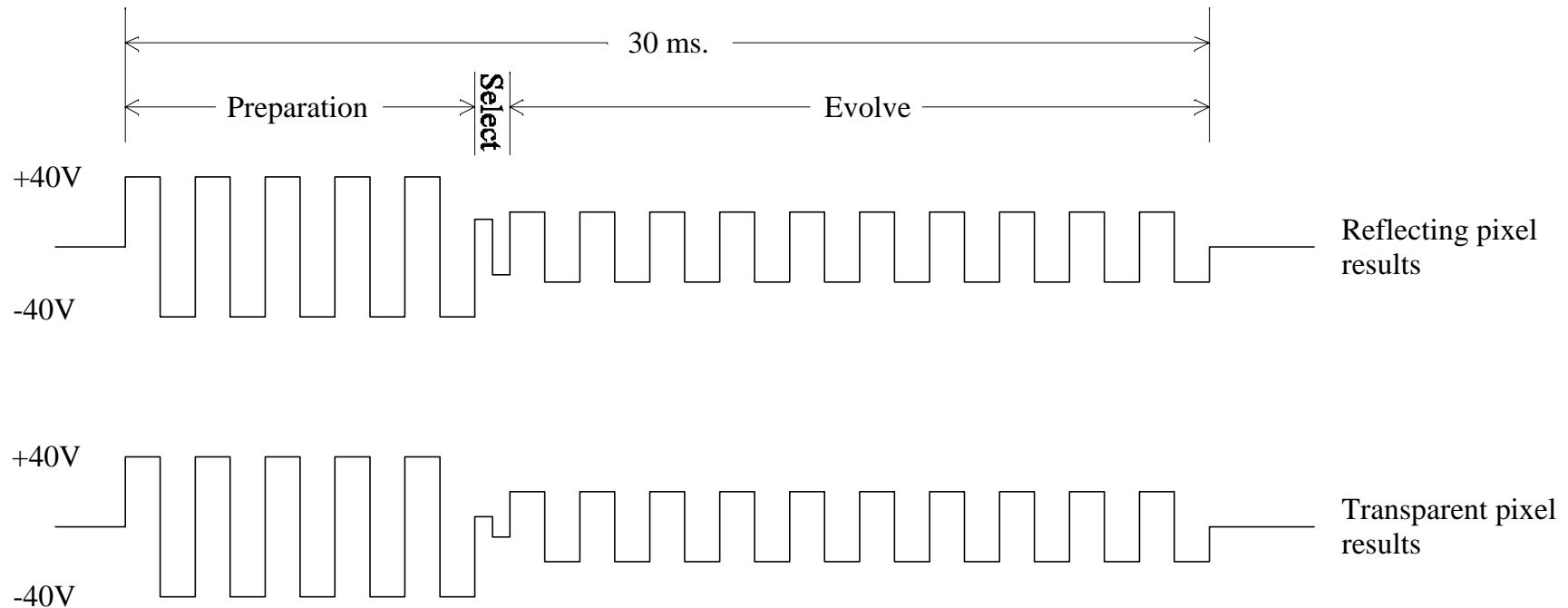

# Cost Considerations

- Display
  - Simple
    - ITO on glass, barrier coat, alignment layer, 4-5 $\mu$ m spacing
    - No backlight, no polarizers
  - Standard materials & manufacturing methods
- Drive Electronics
  - Off-the-shelf components take advantage of existing expertise & manufacturing capacity
  - STN drivers
    - Voltage characteristics & low cost per output

# Dynamic Drive Scheme Modifications

## STN Driver Chip Limitations

- Unipolar output voltage range of 0-40V
  - Recast dynamic drive as a differential drive scheme
  - Modified displays to lower required drive voltages
- STN-Logic: Only one pair of voltage inputs can be applied to the display at a time
  - Break up dynamic drive scheme into three parts

# LCDDS Operating Modes

- Mode 1: Apply  $V_{\text{Preparation}}$  to whole display
  - Row & Column Driver Waveforms - Preparation
- Mode 2: Apply  $V_{\text{Select/Non-Select}}$  to pixels in row being addressed
  - $V_{\text{Evolve}}$  to rows already addressed
  - $V_{\text{Hold}}$  to rows not yet addressed
  - $(V_{\text{Hold}} = V_{\text{Evolve}} = V_{\text{Hold/Evolve}})$
  - Row Driver Waveforms - Select or Hold/Evolve
  - Column Driver Waveform - Data
- Mode 3: Apply  $V_{\text{Evolve}}$  to rows already addressed
  - $V_{\text{Data}}$  to rows finished evolving
  - Row Driver Waveforms - Non-Select or Hold/Evolve
  - Column Driver Waveform - Data

# Low Cost Dynamic Drive Scheme Pixel Waveforms

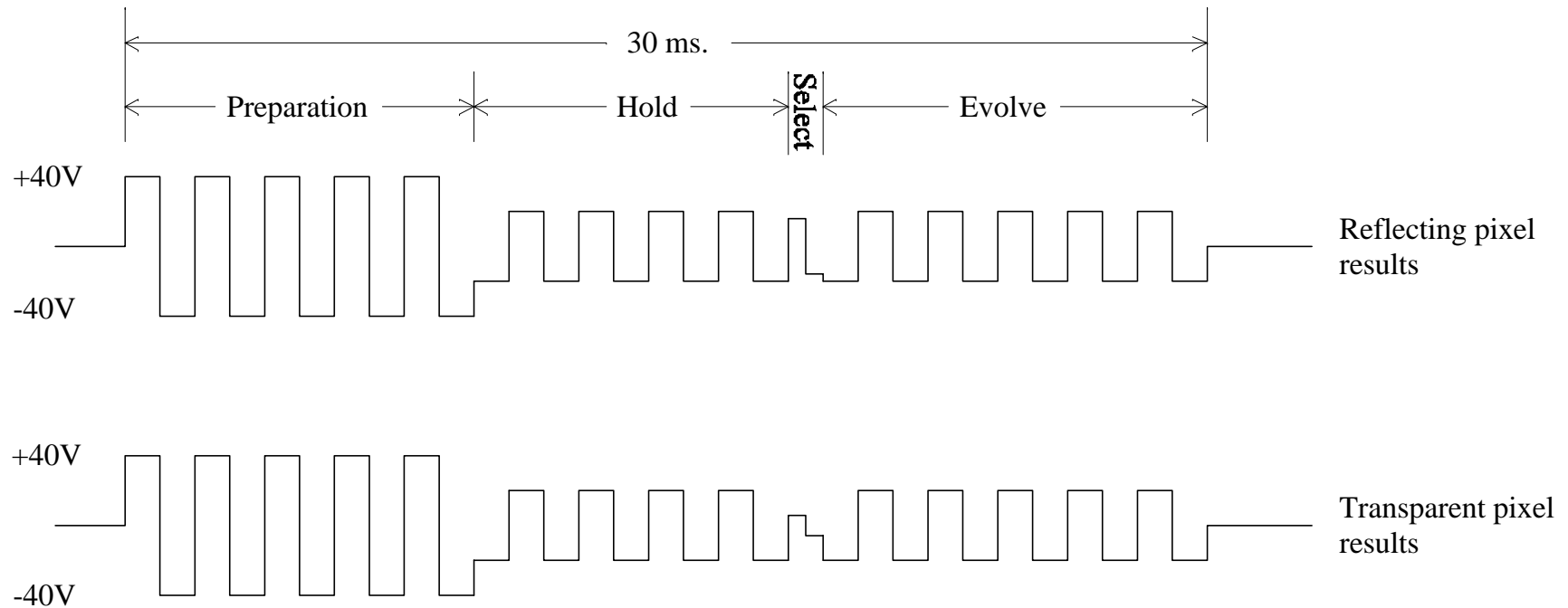

# LCDDS Component Waveforms

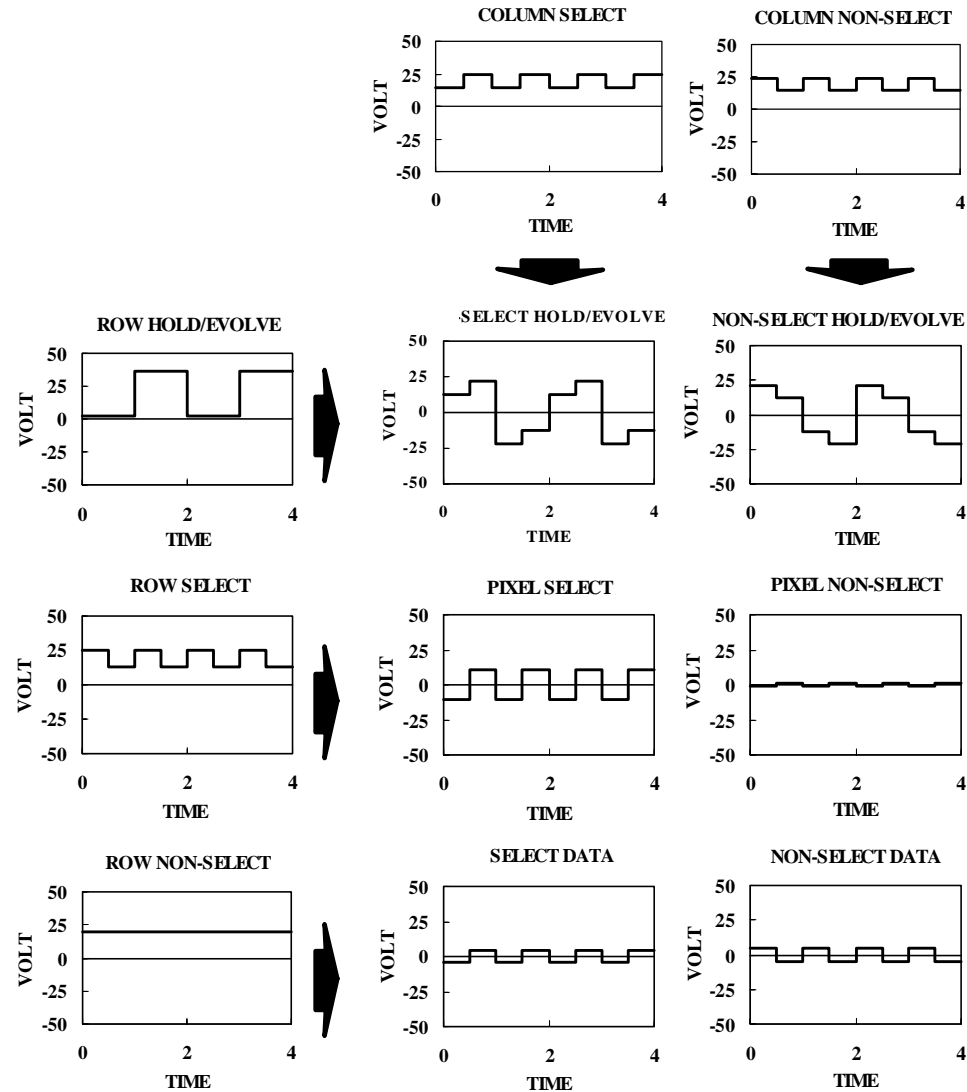

# LCDDS Composite Waveforms

TYPICAL COLUMN

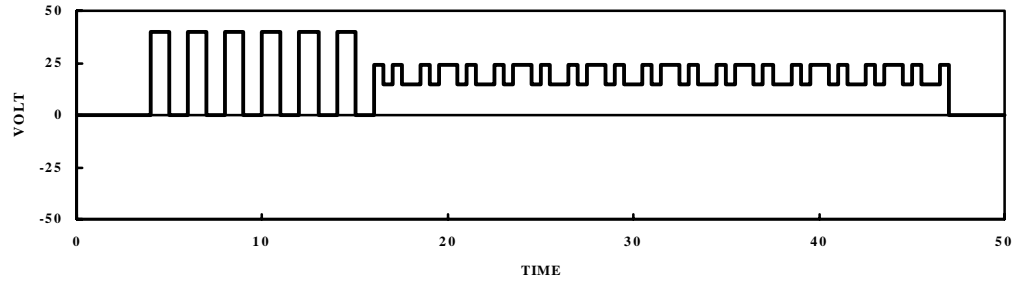

TYPICAL ROW

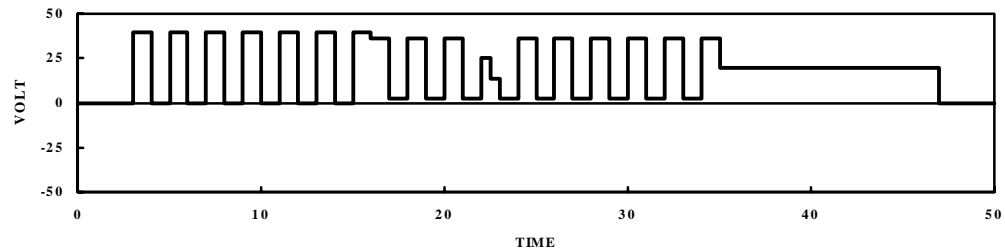

TYPICAL PIXEL

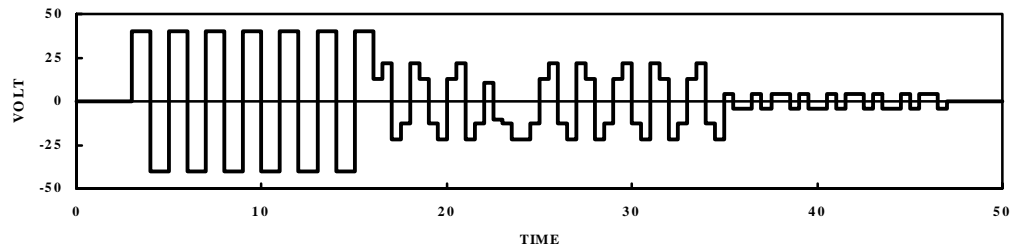

# Driver Chip Impedance Test Circuit

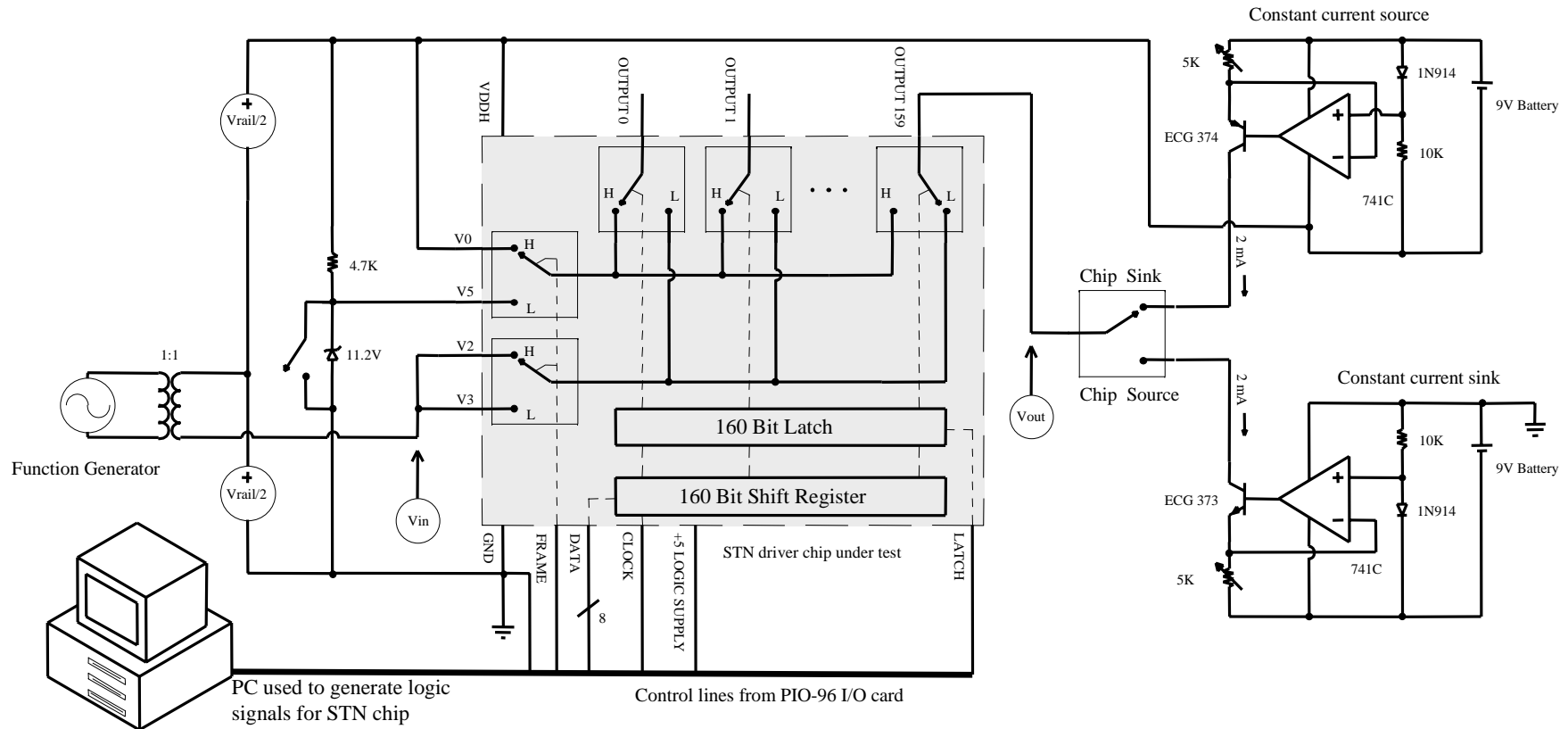

# Typical Driver Chip Impedance Test Results

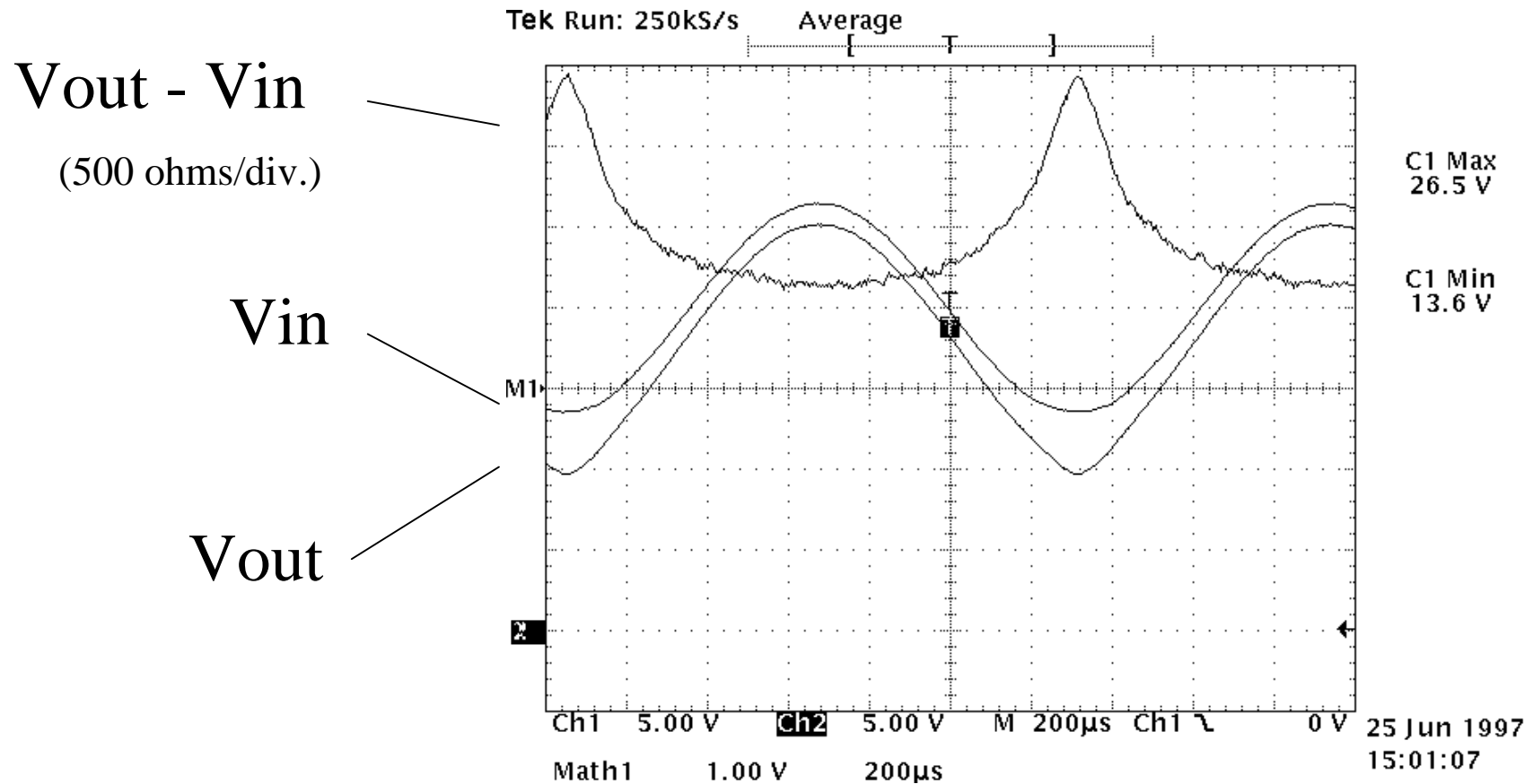

# LCDDS Display Head Block Diagram

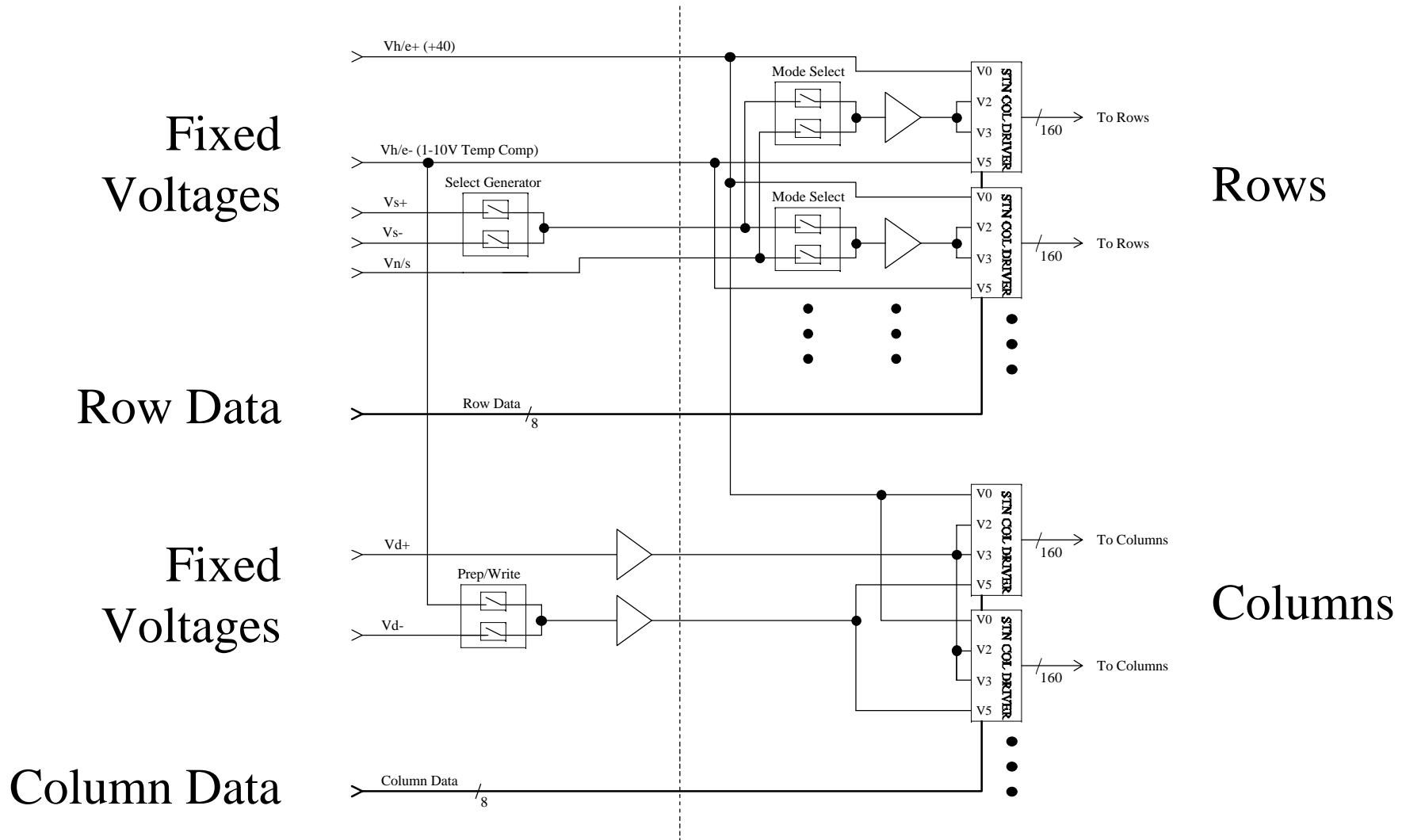

# LCDDS Row Driver Incremental Circuitry

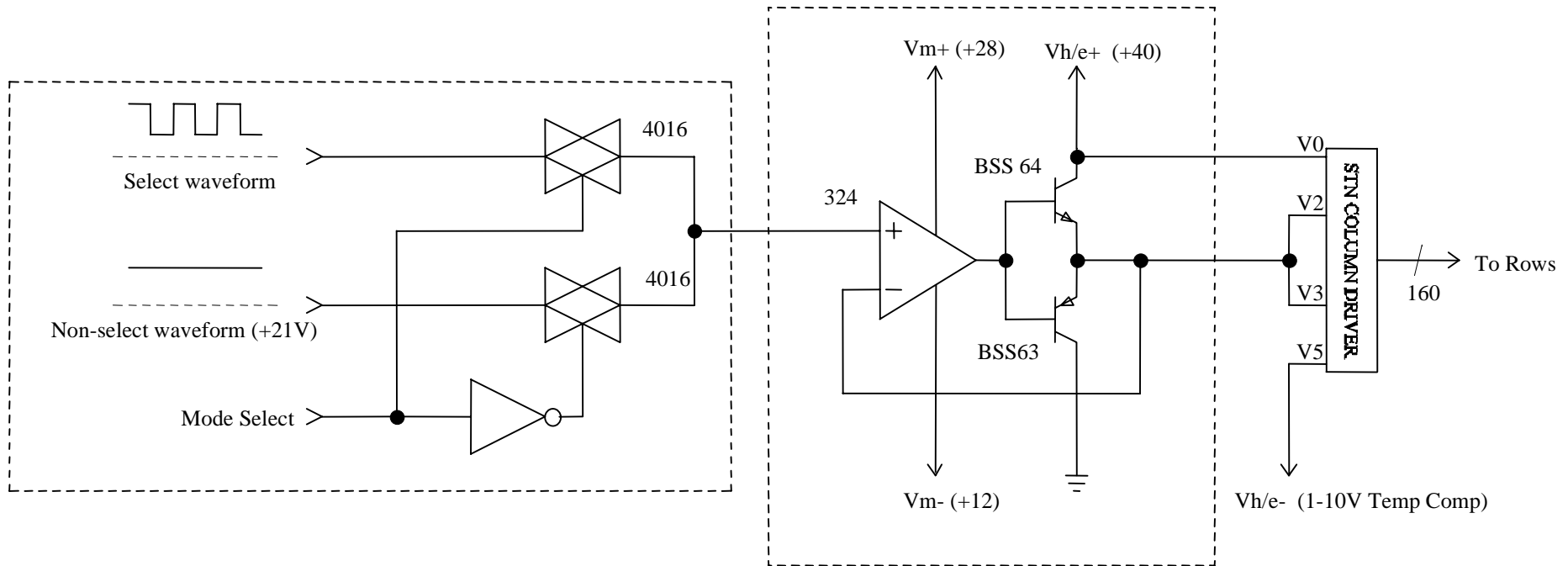

Mode Select Circuit  
(\$0.135)

Buffer Circuit  
(\$0.365)

# LCDDS Voltage Level Generator Circuit

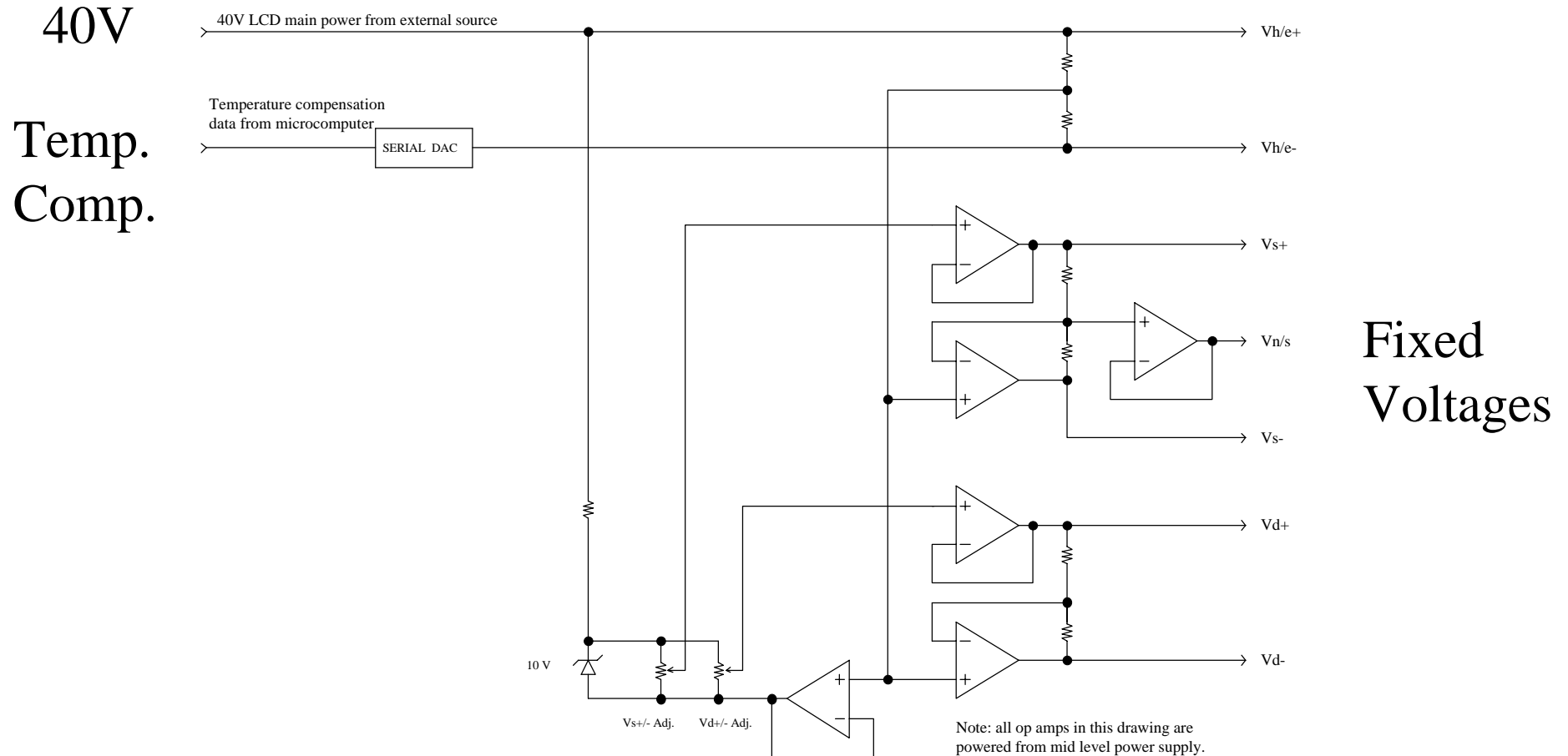

# LCDDS Row Circuit Cost

## VGA Display

Row Circuit Component	Description	Cost (\$)
Driver Chips	3 STN column drivers, 160 outputs ea. (SED 1744 @ \$3.93 ea.)	11.79
Waveform Generation	2 quad bilateral switches (CD4016CM @ \$0.27 ea.)	0.54
Buffer Circuits	1 quad op amp (LM324M @ \$0.34 ea)	0.34
	3 NPN transistors (BSS64 @ \$0.14 ea)	0.42
	3 PNP transistors (BSS63 @ \$0.14 ea)	0.42
<b>TOTAL</b>		<b>13.51</b>

$$\$13.51/480 \text{ Rows} = \$0.028/\text{Row}$$

# LCDDS Display Head Prototype

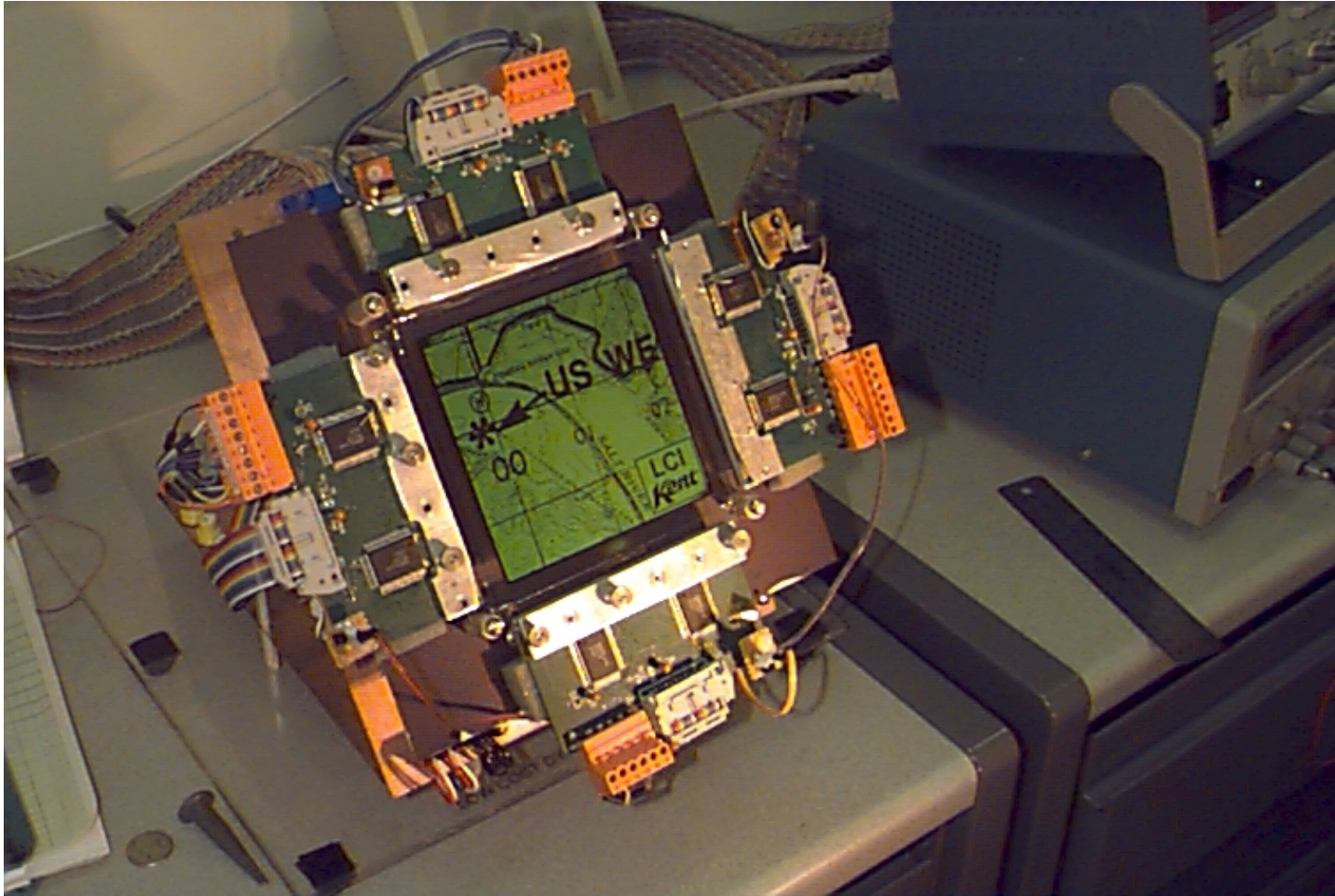

# Conclusions & Acknowledgements

- We have developed a simple, practical, & inexpensive drive scheme for bistable cholesteric liquid crystal displays.
- The low cost dynamic drive scheme can be implemented at a cost of less than \$0.03 per line.
- This could be the lowest cost display technology available.
  
- Work performed under  
DARPA Contract #N61331-94-K-0042